

# Problem set 3 for 41076: Methods in Quantum Computing

due October 10th 2023, in class  
15 points

## 1 Paulis (6 points)

Consider the Pauli matrices,  $\sigma_1 = X$ ,  $\sigma_2 = Y$  and  $\sigma_3 = Z$ :

1. Show that the anticommutator  $\{A, B\} = AB + BA$  for Paulis satisfies

$$\{\sigma_j, \sigma_k\} = 2\delta_{j,k}\mathcal{I} \quad (1)$$

where  $\delta_{k,j}$  is the Kronecker delta,  $\delta_{k,j} = 1$  if  $j = k$  and 0 otherwise.

2. Show that the commutator  $[A, B] = AB - BA$  for Paulis satisfies

$$[\sigma_j, \sigma_k] = i2\epsilon_{j,k,l}\sigma_l \quad (2)$$

Here we use Einstein notation ( $\epsilon_{j,k,l}\sigma_l$  stands for  $\sum_l \epsilon_{j,k,l}\sigma_l$ ) and the Levi-Civita  $\epsilon$  symbol in 3 dimensions. For Levi-Civita,  $\epsilon_{1,2,3} = 1$  and exchanging any two indices satisfies  $\epsilon_{j,k,l} = -\epsilon_{k,j,l}$  (completely antisymmetric). Thus,  $\epsilon_{2,1,3} = \epsilon_{1,3,2} = \epsilon_{3,2,1} = -1$ . Because of the antisymmetry,  $\epsilon_{j,k,l}$  will be zero if any of the indices are equal to each other, i.e.  $\epsilon_{1,1,2} = 0$ .

3. Show that

$$\sigma_j\sigma_k = \delta_{j,k}\mathcal{I} + i\epsilon_{j,k,l}\sigma_l. \quad (3)$$

This is a useful identity if one often multiplies Paulis.

4. Consider Paulis on one qubit

$$P = \{\pm\mathcal{I}, \pm X, \pm Y, \pm Z, \pm i\mathcal{I}, \pm iX, \pm iY, \pm iZ\} \quad (4)$$

Show that  $P$  with multiplication forms a group.

## 2 Clifford gates (5 points)

This problem will demonstrate how stabilizers can be used for efficiently performing certain quantum computations.

1. Consider a state  $|\psi\rangle = |0\rangle|+\rangle$ . Find two two-qubit Paulis  $P_1, P_2$  (other than identity or its multiples) that stabilize this state, i.e.  $P_1|\psi\rangle = P_2|\psi\rangle = |\psi\rangle$ .

2. Compute  $SXS^\dagger$  where  $S$  is the phase gate  $S = \begin{pmatrix} 1 & 0 \\ 0 & e^{-\frac{i\pi}{2}} \end{pmatrix}$

3. Use stabilizers (i.e. not quantum states) to simulate the following circuit. What will be the stabilizers corresponding to the output?

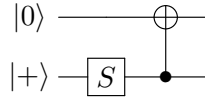

### 3 Complexity of a quantum algorithm (4 points)

The goal of this problem is to estimate the gate complexity and query complexity of a quantum algorithm for computing gradient. Let  $f : \mathcal{R}^d \rightarrow \mathcal{R}$  be a function of  $d$  variables. We would like to estimate its gradient  $\nabla f = \left( \frac{\partial f}{\partial x_1}, \frac{\partial f}{\partial x_2}, \dots, \frac{\partial f}{\partial x_d} \right)$  up to an error  $\frac{1}{\epsilon^2}$ .

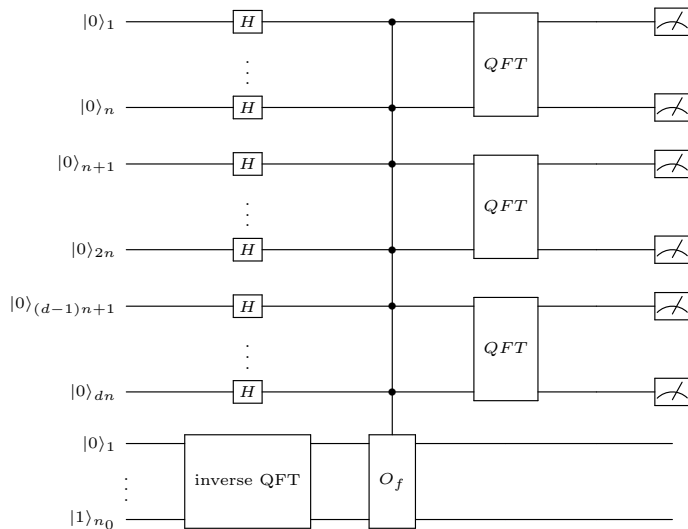

**Figure 1:** A quantum gradient algorithm by Jordan.

1. First, we estimate the complexity of a classical algorithm. For each component of the gradient  $\frac{\partial f}{\partial x_i}$ , we evaluate the function  $f$  in points  $f(x_0, \dots, x_i + \epsilon/2, \dots, x_d)$  and  $f(x_0, \dots, x_i - \epsilon/2, \dots, x_d)$  and compute  $\frac{\partial f}{\partial x_i} \approx \frac{f(x_0, \dots, x_i + \epsilon/2, \dots, x_d) - f(x_0, \dots, x_i - \epsilon/2, \dots, x_d)}{\epsilon}$ . How many queries to  $f$  does this algorithm use? A tight bound in big-O notation is sufficient.
2. A quantum algorithm accesses  $f$  through an oracle  $O_f$  such that  $O_f|x_1, \dots, x_d\rangle|z\rangle = |x_1, \dots, x_d\rangle|z \oplus f(x)\rangle$  where each register  $x_i$  consist of  $n$  qubits and  $z$  a real number encoded into  $n_0$  qubits. The circuit for approximating the gradient is depicted in Fig. 1. It uses  $d$  input register with  $n$  qubits each and an output register with  $n_0$  qubits. First, it performs a Hadamard transform on the input registers and an inverse quantum Fourier transform on the output register. Next, we apply the oracle and lastly apply QFT on each input register. Compute

the gate and query complexity of the algorithm. Big-O asymptotic result in terms of  $d, n$  and  $n_0$  is sufficient.

While this algorithm is indeed very interesting, it does not have a lot of applications in quantum computing because the implementation of the oracle  $O_f$  wipes out the speedup. However, this approach inspired future algorithms for optimization and estimation of expectation values.

#### **4 Bonus: Quantum (2-4 points)**

Pick a wrong or misleading claim about quantum computing/mechanics/information/computing, theory or experiment and explain the issues with this claim. The claim can be from a respected media publication (NY Times yes, Medium no), a publicly available claim from a quantum scientist or CEO/VP of a quantum company. Use references to quantum literature to support your argument and acknowledgements when appropriate. Note that your argument does not need to be original, only well-researched and articulated. The minimum length is 100 words and the maximum 1 page, excluding references. Please try to find a different claim than your classmates.